



## FL1V3 Capacitive Filter - US Standards Manual

Model: FL1V3 (120~600V)

Category: Passive Capacitive Filter / Compact Multi-Functional Filter

Intended Use: Industrial / Commercial / Residential Power Quality Filter



# Table of Contents

- ..... 1
- FL1V3 Capacitive Filter - US Standards Manual..... 1
- Table of Contents** ..... 2
- 1. GENERAL SAFETY INFORMATION** ..... 3
  - 1.1 Qualified Personnel Requirement** ..... 3
  - 1.2 Personal Protective Equipment (PPE)** ..... 3
  - 1.3 De-Energization Requirement** ..... 3
  - 1.4 Grounding and Bonding**..... 3
- 2. TECHNICAL SPECIFICATIONS** ..... 4
- 3. TOOLS AND MATERIALS** ..... 4
- 4. INSTALLATION PROCEDURE** ..... 4
  - 4.1 Pre-Installation Checklist** ..... 4
  - 4.2 Mounting**..... 5
  - 4.3 Wiring**..... 5
- 5. SYSTEM COMMISSIONING** ..... 5
  - 5.1 Initial Power-Up** ..... 5
  - 5.2 Verification** ..... 6
- 6. TROUBLESHOOTING GUIDE** ..... 6
- 7. ELECTRICAL DISTURBANCE PROTECTION** ..... 6
- 8. COMPLIANCE & CERTIFICATION** ..... 7
- 9. WARRANTY INFORMATION**..... 8
- Detailed Explanation of Technical Parameters** ..... 8
  - 1. Input Voltage Range: 120 – 600V AC** ..... 8
  - 2. Frequency Range: 45 – 65 Hz** ..... 9
  - 3. Mounting Type: DIN Rail (35mm) or Panel Mount**..... 9

4. Operating Temperature: -4°F to 140°F (-20°C to +60°C).....	9
5. Dimensions: 6.5" x 4.5" x 3.3" .....	9
6. Weight: ~1.9 lbs (27 oz).....	10
7. Protection Class: IP55.....	10

## 1. GENERAL SAFETY INFORMATION

### 1.1 Qualified Personnel Requirement

Only licensed electricians or technicians trained in electrical systems and power quality should install and maintain this equipment.

All work must comply with **NFPA 70 (NEC)**, **OSHA 29 CFR 1910 Subpart S**, and local building and electrical codes.

### 1.2 Personal Protective Equipment (PPE)

Per **OSHA requirements**, the following PPE must be worn during installation and servicing:

- Class 0 or higher **electrical-insulating gloves**
- **Leather protectors** over gloves
- **Arc-rated clothing** (minimum Category 2)
- **Dielectric footwear**
- **Face shield** with arc flash protection
- **Class E hard hat**

### 1.3 De-Energization Requirement

- All power sources must be de-energized before work begins.
- Use **lockout/tagout (LOTO)** procedures per **OSHA 1910.147** to prevent accidental energization.

### 1.4 Grounding and Bonding

- Grounding must comply with **NEC Article 250**.

- Ground resistance must be **less than 10 ohms**, verified using an approved clamp meter or earth tester.
- As a parallel passive device, Flowāv requires a low-impedance ground connection (<10Ω) for optimal EMI suppression and safety.

## 2. TECHNICAL SPECIFICATIONS

Parameter	Specification
<b>Input Voltage Range</b>	120 – 600V AC
<b>Frequency</b>	45 – 65 Hz
<b>Mounting Type</b>	DIN Rail (35mm) or Panel Mount
<b>Operating Temperature</b>	-4°F to 140°F (-20°C to +60°C)
<b>Dimensions (Approx.)</b>	6.5" x 4.5" x 3.3"
<b>Weight</b>	~1.9 lbs (27 oz)
<b>Protection Rating</b>	IP55 (without enclosure)
<b>Surge Suppression System</b>	Up to 680V

## 3. TOOLS AND MATERIALS

- Insulated screwdriver set
- TRUE RMS multimeter
- 4.0 mm<sup>2</sup> (or 12 AWG) copper wire
- 10A UL-listed circuit breaker (1 per unit)
- DIN rail (35 mm)
- Cable tray or conduit (if needed)
- High-temp electrical insulation tape
- Earth resistance tester (clamp meter preferred)
- Grounding rod and clamp

## 4. INSTALLATION PROCEDURE

### 4.1 Pre-Installation Checklist

- Inspect panel enclosure for moisture, dirt, or damage.
- Confirm product voltage rating matches the system.
- Check that grounding resistance is less than 10 ohms.

## 4.2 Mounting

- Mount device on DIN rail or securely fasten to panel using screws.
- Use UL Certified IP65/NEMA 4X enclosure if installed in harsh environments.



## 4.3 Wiring

- **L1, L2, L3** (Input Voltage Terminals):  
Connect in parallel across the phases (L1-L2-L3).
- **Neutral** (N):  
Connect if using line-to-neutral measurement.
- **Ground (GND):**  
Bond to facility's ground electrode system per NEC.

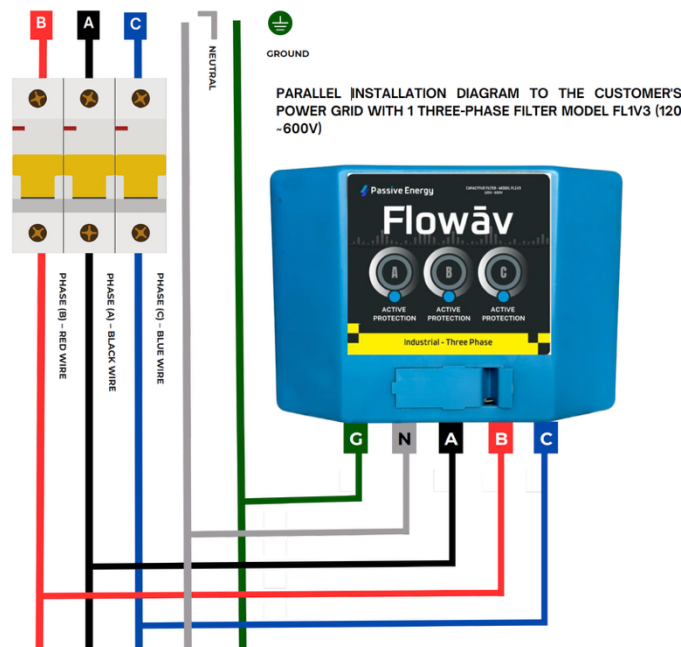

## 5. SYSTEM

### 5.1 Initial Power

- Apply power by activating breaker and observe LED indicators:
  - If all 3 LEDs on: GOOD
  - If 1 or more LEDs off: CHECK WIRING

## 5.2 Verification

- Use test equipment if available. I.E Fluke 1738

## 6. TROUBLESHOOTING GUIDE

Symptom	Cause	Solution
No LED / No operation	No power input	Check breaker and wiring
No Performance Detected	Poor grounding or installation	Check grounding and verify correct parallel wiring
Overheating	Poor airflow or overload	Ensure proper ventilation, verify panel load
High THD	Incorrect parameters	Ensure Flowāv units are installed per kWh and project guidelines

## 7. ELECTRICAL DISTURBANCE PROTECTION

This device provides passive power quality correction by:

- Suppressing high-frequency electrical noise
- Filtering harmonic content through capacitive means
- Reducing total harmonic distortion (THD) and EMI interference
- Operating as a passive, parallel-installed filter to improve power factor
  - Over/undervoltage
  - Phase imbalance
  - Voltage fluctuations (flicker)
  - Harmonics and non-linear load artifacts
  - Arc furnace and motor start disturbances
  - Oscillatory/impulsive transients
  - Overuse of reactive power

Note: Flowāv does not actively monitor voltage. It is not a relay.

## 8. COMPLIANCE & CERTIFICATION

Complies with:

1. *UL Listed: FOKY.E539580– Electromagnetic interference (EMI) filters installed in equipment connected to 1000 V, 50 - 60 Hz or 1500 V, dc or lower potential circuits, and installed in accordance with ANSI/NFPA 70, "National Electrical Code."*
2. *IEC 60950 (2005) - Safety of information technology equipment.*
3. *ABNT NBR 5410 (2004) - Resolution No. 529 - Low Voltage Electrical Installations.*
4. *IEC 61000-4-2 - Electrostatic discharge immunity test.*
5. *IEC 61000-4-5 - Surge Immunity Test.*
6. *NBR IEC 61643-1 - Low voltage surge protection devices.*
7. *IEC 61000-3-2 - Limits for emission of current harmonics (<16 A per phase).*
8. *IEC 61000-3-4 - Limits for emission of current harmonics (>16 A per phase).*
9. *IEEE 519 - Requirements for harmonics control in the electrical power system.*
10. *NBR 5456 (1987) - General Electricity Terminology.*
11. *IEEE-519 (1991) - Additional reference to harmonics control requirements.*
12. *IEEE Task Force (1982) - Reference to power quality research.*
13. *QT81BB (2008) - Power factor correction and Harmonic Filtering in electrical plants.*
14. *AIEE Transactions (1961) - Optimization of shunt capacitors for reactive-volt-ampere control and loss reduction.*
15. *AIEE Transactions (1956) - Similar to the above, focused on shunt capacitor applications.*
16. *IEEE Electrical Insulation Magazine (2015) - Insulation failure mechanisms of power generators.*

17. *IEEE Transactions on Power Delivery (1991) - Practical design of generator surge protection.*

18. *General Electric TIS Report 75CRD039 (1973) - High-voltage impulse testers.*

19. *IEEE Transactions on Power Systems (2011) - Strategies for minimizing energy losses through optimized renewable energy integration.*

## 9. WARRANTY INFORMATION

- **Coverage:** 10-year limited warranty
- **Includes:** LED failure, internal fault (non-tampered devices)
- **Required for Claim:** Proof of purchase (invoice or warranty document)

Contact your authorized distributor for service or replacement.

## Detailed Explanation of Technical Parameters

---

Parameter	Detailed Description
-----------	----------------------

---

### 1. Input Voltage Range: 120 – 600V AC

This defines the acceptable **operating voltage** range for the device.

- **120V AC to 600V AC** is the **line-to-line (L-L)** or **line-to-neutral (L-N)** voltage the device can safely monitor.
- The device can be used in **single-phase, two-phase, and three-phase** systems.
- Using voltages outside this range may cause the unit to malfunction or be damaged.

Ensure your system voltage falls within this range before installation.

## 2. Frequency Range: 45 – 65 Hz

This is the acceptable **input frequency** range.

- Most utility systems operate at **50 Hz or 60 Hz**.
- The device is designed to ignore minor fluctuations, but it won't function properly with unstable or non-standard frequencies (e.g., generator output beyond range).

## 3. Mounting Type: DIN Rail (35mm) or Panel Mount

This refers to the **physical installation method**.

- **DIN Rail:** Common in control cabinets; the device snaps onto a standard 35mm metal rail.
- **Panel Mount:** Can also be screwed into a panel backplate if needed.

Use DIN rail unless you're integrating directly into a panel without rail infrastructure.

## 4. Operating Temperature: -4°F to 140°F (-20°C to +60°C)

This is the **environmental temperature** range where the device can function reliably.

- Operating below -4°F may cause the electronics to become unstable.
- Operating above 140°F can result in overheating or premature component failure.

Install in **enclosures** and avoid direct sunlight or heat sources.

## 5. Dimensions: 6.5" x 4.5" x 3.3"

This defines the **physical size** of the device.

- Helps in planning the **space allocation** inside control panels or enclosures.

## 6. Weight: ~1.9 lbs (27 oz)

The total **weight** of the unit (likely including internal filter components and casing).

- Useful for determining **mounting stability** or calculating shipping.
- Make sure DIN rail or panel mounts are strong enough to hold the unit securely.

## 7. Protection Class: IP55

This specifies the **ingress protection rating** of the device:

- **Dust Protection:** Complete protection against harmful dust ingress. Limited dust penetration is permitted but cannot affect operation.
- **Water Protection:** Protected against low-pressure water jets from any direction (6.3 mm nozzle at up to 12.5 L/min).
- **Impact:** Rugged enclosure designed to withstand typical industrial and commercial environments.
- The device must be installed **inside a UL Certified electrical enclosure.**
- Use an IP65-rated enclosure for dust/water resistance when required.